

## VACUUM CHAMBER PACKING

# Idea 30

The Idea Line includes all the advantages of Orved technology: absolute vacuum sensor for perfect vacuum in all circumstances, hydroformed vacuum chamber for long-lasting quality and ease of cleaning, power sealing for multiple sealing of overlapping vacuum bags.

Thanks to its internal sensors, the packaging machines of the idea line, can ensure a perfect vacuum in any conditions with any type of product, food or non-food or liquids.

The digital control panel includes a memory of 10 vacuum programs, with the possibility on Idea 31 and Idea 41 to add gas (optional) or to perform a deaeration program (degas) to create special vacuum cycles for every customer's need.

The robust chamber with rounded steel edges allows easy cleaning after use.



## Technical specifications

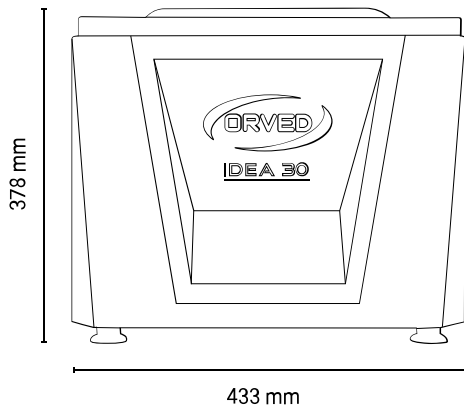

### IT CAN PACK:

Liquids

Solids

Delicate foods

**BODYWORK**  
Stainless steel

**VACUUM PUMP**  
8mc/h

**MAX VACUUM LEVEL**  
2 mbar

**DIMENSIONS**  
425x504x398h mm

**VACUUM CHAMBER DIMENSIONS**  
334x351x170h mm

**WEIGHT**  
35,3 kg

**VOLTAGE**  
220-240V / 50-60Hz - 600W

**MAX BAG DIMENSIONS**  
300 x 350 mm

**SEALING BAR**  
315 mm

# Kits



**Digital panel**



**Easy external vacuum**



**Pump dehumidification**



**User programs**



**Vacuum on containers**



**Vacuum sensor**