

HEAVY DUTY

# Bright 18

Tisch-Vakuumkammermaschine, komplett aus Edelstahl, ausgestattet mit einem intelligenten Vakuumsensor und der innovativen Chef Programs-Technologie für ein perfektes Vakuum von Lebensmitteln und Non-Food-Produkten.

Wasserdichtes digitales Bedienfeld mit 32 Programmen, einschließlich exklusiver voreingestellter Programme von professionellen Köchen, Entlüftungsprogrammen (Degas) und Vakuumprogrammen für interne oder externe Behälter. Der Entfeuchtungszyklus der H2Out-Pumpe garantiert eine perfekte Wartung der 25-mc / h-Vakuumpumpe. Es ist mit einer kabellosen Dichtungsstange mit einer Länge von 415 mm ausgestattet.



## Technische Daten

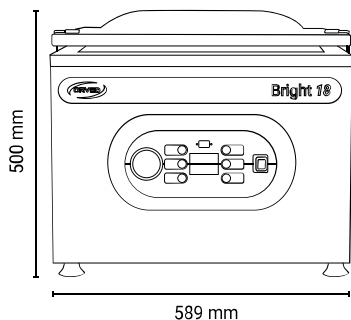

### KANN VERPACKEN

Flüssigkeiten

Feststoffe

Empfindliche Lebensmittel

### IDEAL ZUM

Restaurants, Hotels, Catering, Metzger, Molkereien, Lebensmittel labore

**GEHÄUSE**  
Edelstahl

**VAKUUMPUMPE**  
25mc/h

**MAXIMALES VAKUUMNIVEAU**  
2 mbar

**ABMESSUNGEN**  
589 x 587 x 501h mm

**ABMESSUNGEN DER VAKUUMKAMMER**  
440x448x200h mm

**GEWICHT**  
76 kg

**SPANNUNG**  
220-240V / 50-60Hz - 1600W

**MAX. BEUTELABMESSUNGEN**  
400 x 500 mm

**SCHWEISSLEISTE**  
415 mm

**INSTALLATION**  
Theke

## Details



Vakuunkammer



Vakuum - Gas



Digitales Bedienfeld

## Ausstattungen



Digitales Panel



USB-Anschluss



Benutzerprogramme



Kochprogramme



Pumpenentfeuchtung



Einfaches externes Vakuum



Gasvakuum (MAP)



Doppelte Abdichtung



Vakuumsensor



Abnehmbare Gegenstange

### AUF ANFRAGE



Absperrdichtung



In externen Behältern absaugen



Softair



Doppelter Datumsstempel



WI-FI-Modul

## Smart-Programme



Marinieren



Saucen



Dicke Saucen



Feststoffe und Füllungen



Gaswäsche



Gebäckbasen



Eisböden



Fleisch



Hähnchen



Fisch



FrISChe Pasta

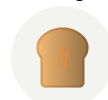

Bäckereiprodukte



Gemüse



Nachspeisen



Pulver und Gewürze

