

HEAVY DUTY

# Bright 1800

Vakuumkammermaschine, komplett aus Edelstahl, ausgestattet mit einem intelligenten Vakuumsensor und der innovativen Chef Programs-Technologie für ein perfektes Vakuum von Lebensmitteln und Non-Food-Produkten.

Wasserdichtes digitales Bedienfeld mit 32 Programmen, einschließlich exklusiver voreingestellter Programme von professionellen Köchen, Entlüftungsprogrammen (Degas) und Vakuumprogrammen für interne oder externe Behälter. Der Entfeuchtungszyklus der H2O-Out-Pumpe garantiert eine perfekte Wartung der Vakuumpumpe mit 60 mc / h. Es ist mit zwei kabellosen Dichtungsstangen mit einer Länge von jeweils 860 mm ausgestattet.



## Technische Daten

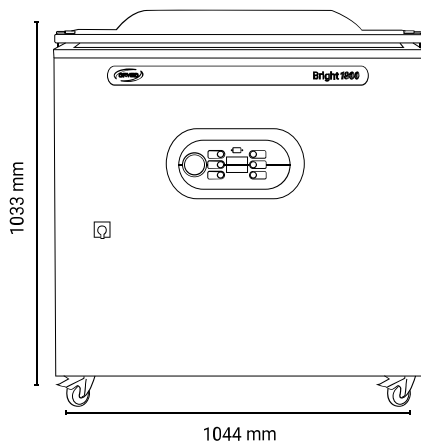

### KANN VERPACKEN

Flüssigkeiten

Feststoffe

Empfindliche Lebensmittel

### IDEAL ZUM

Catering, Metzgereien, Molkereien, Lebensmittel Labors

**GEHÄUSE**  
Edelstahl

**VAKUUMPUMPE**  
60mc/h

**MAXIMALES VAKUUMNIVEAU**  
2 mbar

**ABMESSUNGEN**  
1044 x 606 x 1033h mm

**ABMESSUNGEN DER VAKUUMKAMMER**  
903x463x200h mm

**GEWICHT**  
197 Kg

**SPANNUNG**  
400V 50/60Hz 3ph +PE  
2200W

**MAX. BEUTELABMESSUNGEN**  
variabel

**SCHWEISSLEISTE**  
2 x 860 mm (alternative: 2 x 415 mm)

**INSTALLATION**  
mit Wagen

## Details



Vakuunkammer



VAKUUM - GAS (OPTIONAL)



Digitales Bedienfeld

## Ausstattungen



Digitales Panel



Vakuumsensor



Doppelte Abdichtung



Pumpenentfeuchtung



Kochprogramme



Benutzerprogramme



USB-Anschluss



Abnehmbare  
Gegenstange

### AUF ANFRAGE



Absperrdichtung



In externen  
Behältern absaugen



Gasvakuum (MAP)



Softair



WI-FI-Modul

## Smart-Programme



Pulver und  
Gewürze



Nachspeisen



Marinieren



Saucen



Dicke  
Saucen



Fleisch



Hähnchen



Fisch



Bäckereipro-  
dukte



Gemüse



Frische  
Pasta



Eisböden



Gebäckbase  
n



Gaswäsche



Feststoffe  
und  
Füllungen

