

# Bright 53



WiFi-Modul



Doppelte Schweißnaht\*



Verpackt mehrere Produkte gleichzeitig



## Höchste Funktionalität und Zuverlässigkeit!

Exklusive Vakuumverpackungsmaschinen mit „Automatenstahl“-Vakuumkammer, Doppelschweißung, Anlage zur Inertbegasung, i-Sensor (sensorgesteuertem Vakuumsystem), EASY-System für maximales, auch externes Vakuum.

### Bright 53 Ideal für:



Restaurants



Hotels



Catering



Fleischereien



Käsereien



Lebensmittelwerkstätten

### Verpackungsmethoden:



Nur Versiegelung



Vakuum



Externes Vakuum



MAP

## Koch- und Behälterprogramme inbegriffen:



Fleisch



Huhn



Fisch



Feste Lebensmittel/  
Füllungen



Saucen



Dicke Saucen



Marinaden



Backwaren



Gemüse



Pulver und  
Gewürze



Süßspeisen



Creme-Präparate  
zum Backen



No stop



Behälter sensor



Behälter MIN



Behälter MED



Behälter MAX







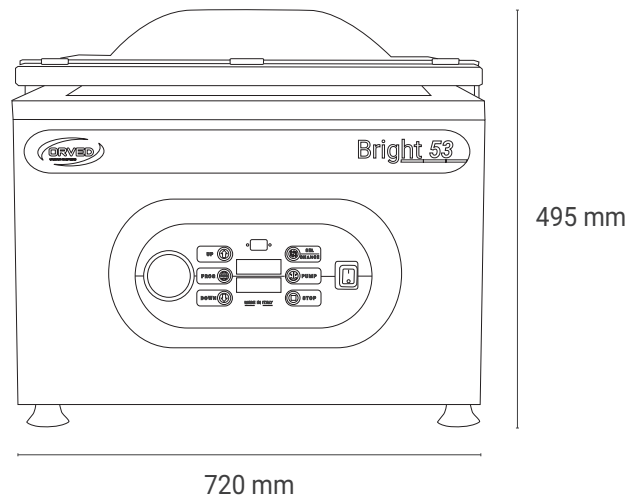

Behälter extreme

## DATENBLÄTTER







- > Maschinenkörper: Edelstahl
- > Aussenmass: 720x720x495h mm
- > Vakuumkammermass: 575x575x160h mm
- > Gewicht: 105 kg
- > Spannung: 220-240V 50/60Hz
- > Maximal Aufgenommene Leistun:
  - 1500W (1 Schweißbalken)
  - 2300W (2 Schweißbalken)
- > Schweißbalken: 1x 530 mm  
2x 530 mm (optional)
- > Vakuumpumpe: 25 mc/h
- > Maximal Aufgenommene Leistun: 500x500 mm
- > Abstand Der Langen Balken: 481 mm



## Serienausstattung

-  Digitales Bedienfeld, 48 Programme
-  Gas
-  USB-Schnittstelle für Firmware-Updates
-  Sensorgesteuertes System für absolutes Vakuum
-  H2out, Pumpenentfeuchtungsvorgang
-  Gegenhalter abnehmbar
-  Doppelte Schweißnaht\*

## Optional auf anfrage

-  Abtrennung des Beutelüberstands\*
-  Easy, externe Vakuumerzeugung
-  Softair
-  Düse für Behälter
-  WiFi-Modul
-  Kit Glatte Vakuumbbeutel - PREMIUM

## Zubehör



Glatte Vakuumpreservierungsbeutel



Goffrierte Vakuumpreservierungsbeutel



Glatte Vakuumpreservierungsbeutel



Unterwagen



„ConserBox“-Behälter



„Easy“-Zubehör für externes Vakuum



Einlegebleche